

Model 340AJ

ARTICULATING BOOM LIFTS



Features

- 4 ft (1.22 m) Articulating Jib
- 355 Degree Non-Continuous Swing
- Platform 30 x 60 in. (0.76 x 1.22 m) Side Entry
- 180 Degree Hydraulic Platform Rotator
- Platform Console Machine Status Light Panel*
- 110V-AC Receptacle in Platform
- 5 Degree Tilt Alarm/Indicator Light
- 9 x 20 Lug Tread Pneumatic Tires
- Swing-Out Engine Tray
- Gull-Wing Steel Turntable Hoods
- 12V-DC Auxiliary Power
- Hourmeter
- Hydrostatic Drive
- Proportional Controls
- Control ADE® System
- Lifting/Tie Down Lugs
- Horn
- Oscillating Axle
- Cast Aluminum Control Box
- All Motion Alarm
- Glow Plugs (Diesel Engines)

* Provides indicator lights at platform control console for system distress, low fuel, 5 degree tilt light, and foot switch status.

Accessories & Options

- 30 x 48 in. (0.76 x 1.22 m) Platform
- Self-Closing Gate
- Mesh to Top Rail (Bolt-on Aluminum)
- 1/2 in. Air Line to Platform
- 9 x 20 Foam-Filled Lug Tires
- 9 x 20 Non-Marking Pneumatic Tires
- 9 x 20 Non-Marking Foam-Filled Tires
- 7 x 18 Solid Cushion Lug Tread Tires
- 7 x 18 Non-marking Solid Cushion Lug Tread Tires
- AC Generator
- 43.5 lb (19.7 kg) Propane Tank
- Chassis Illumination Lights
- Platform Worklights
- Cold Weather Start Kit¹
- Hostile Environment Kit²
- Flashing Amber Beacon
- Arctic Package³ (diesel only)
- Special Hydraulic Oils

1. Includes engine block heater, battery heater, oil tank heater.

2. Includes console cover, boom wipers and cylinder bellows.

3. Includes arctic hydraulic hoses (drive and steer only) and main boom cable, arctic hydraulic oil, extreme cold engine oil, anti-freeze (Cat only), fuel conditioner, engine block heater, battery blanket, glow plugs, hydraulic tank heater, and oversized footswitch.



Increased Productivity

- Ideal for general contractors, steel erectors, painters, stadium construction and more
- Standard articulating jib increases access in confined areas
- Improved rough terrain capabilities with 45% gradeability

Enhanced Control

- Exclusive Control ADE® (Advanced Design Electronics) system for better performance with improved serviceability

Improved Maintainability

- Lower cost of ownership
- Steel hoods provide added durability
- Environmentally-friendly Tier 4 diesel engine
- Lower gross vehicle weight

Model 340AJ

ARTICULATING BOOM LIFTS

Specifications

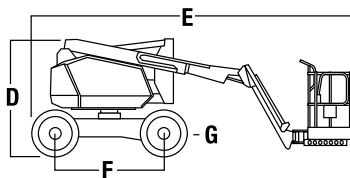
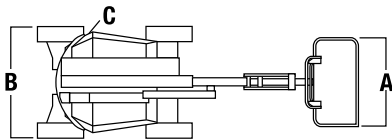
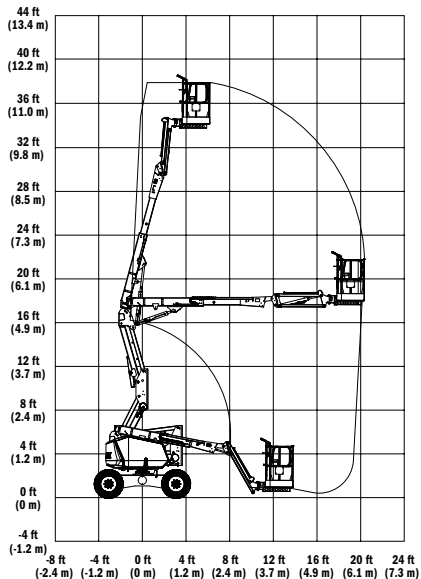

Reach Specifications

Platform Height	33 ft 10 in. (10.31 m)
Horizontal Reach	19 ft 11 in. (6.06 m)
Up and Over Height	17 ft (5.17 m)
Swing	355 Degrees Non-Continuous
Platform Capacity	500 lb (227 kg)
Platform Rotator	180 Degrees° Hydraulic
Jib Length	4 ft (1.22 m)
Jib Range of Articulation	144 Degrees (+84, -60)

Dimensional Data

A. Platform Size	30 x 60 in. (0.76 x 1.22 m)
B. Overall Width	6 ft 4 in. (1.93 m)
C. Tailswing	2 in. (5.08 cm)
D. Stowed Height	6 ft 7 in. (2 m)
E. Stowed Length	18 ft 2 in. (5.52 m), 13 ft (3.98 m) with Jib Stowed
F. Wheelbase	6 ft 2 in. (1.87 m)
G. Ground Clearance	10 in. (23.7 cm)
Weight*	9,700 lb (4,400 kg)
Max. Ground Bearing Pressure	151 psi (10.6 kg/cm ²)

Chassis

Drive Speed 4WD	3.1 mph (4.98 km/h)
Gradeability 4WD	45%
Tires	265/50D20 Lug Tread
Turning Radius (Inside/Outside)	5 ft (1.52 m)/ 13 ft (3.96 m)

Power Source

Dual Fuel Engine	
PSI/GM	28.7 hp (21.4 kW)
Diesel Engine	
Kubota D1105	24.8 hp (18.5 kW)
Fuel Tank Capacity	13 gal (498.2 L)
Hydraulic Reservoir	20.6 gal (77.9 L)
Auxiliary Power	12V DC

* Certain options may increase weight.



The JLG "1 & 5" Warranty

JLG Industries, Inc. backs its products with its exclusive "1 & 5" Warranty. We provide coverage on all products for one (1) full year, and cover all specified major structural components for five (5) years. Due to continuous product improvements, we reserve the right to make specification and/or equipment changes without prior notification. This machine meets or exceeds applicable OSHA Regulations in 29 CFR 1910.67, 29 CFR 1926.453, ANSI A92.5-2006, and CSA Standard CAN3-B354.2-M82, as originally manufactured for intended applications.



JLG Industries, Inc.
 1 JLG Drive
 McConnellsburg, PA 17233-9533
 Telephone 717-485-5161
 Toll-free in US 877-JLG-LIFT
 Fax 717-485-6417
www.jlg.com
 An Oshkosh Corporation Company

Form No.: SS-340AJ-12-20010
 Part No.: 3131121S
 R061202
 Printed in USA