

800 Series

ARTICULATING BOOM LIFTS



**Extra Reach
and Versatility**



**Narrow Fixed
Width - Low GVW**



**Proven Jobsite
Performance**



**800A
800AJ**

www.jlg.com

JLG

Performance at the Highest Level Yet

QuikStik® Boom Provides Optimum Productivity

You asked for faster duty cycles up and down—so we invented the exclusive QuikStik® boom. This boom design allows the platform to be lowered to the ground while the tower boom is fully raised and extended. What's more, it links two lifting actions, simultaneously raising both the upper boom and the tower boom. With this feature, the operator can go from ground level to full elevation in less than 50 seconds.



High Capacity

A platform capacity of up to 1,000 lbs. (454 kg) on the Model 800A increases your productivity by allowing more workers and materials in the platform. This is especially critical for applications requiring extra capacity such as steel erection, mechanical contracting and glazing.

Options to Create Your Workstation in the Sky™ Product

Transform your Model 800A or 800AJ into a true Workstation in the Sky™ product with exclusive options and accessories from JLG. Whether designed for a specific application like the SkyWelder™ Package or to meet a variety of needs like the SkyPower™ Package, JLG has many options available to increase your productivity and enhance your work environment.



The Industry's Best Reach Envelope

You want an optimal reach envelope—and we deliver 32 ft. (9.75 m) of up and over clearance concurrent with 51 ft. 10 in. (15.8 m) of horizontal outreach.



Oscillating Axle for Rough Terrain Performance

With JLG's oscillating axle, you get a smoother ride and better traction. Designed to eliminate the need for extendible axles, the chassis width is a narrow and constant 8 ft. (2.44 m) to reduce set-up and increase productivity.



SkyPower™ Package

JLG delivers more power where you need it with the SkyPower™ Package. Machines outfitted with the SkyPower Package include a 7500W self-contained generator, plus a power cable and a 1/2 inch air line routed through the boom's power track to the platform. As an added benefit, the SkyPower Package is designed to work with various add-on accessories, including the SkyWelder™ Package.

SkyWelder™ Package

A Miller® welder is tucked into the SkyPower™ boom platform. Conserves space and provides stick and TIG capability. It also eliminates potentially dangerous leads hanging over the rails and the cost of a stand-alone welder and power supply. Wire feed capability and other convenient features are available.



SkyGlazier™ Package

The first and only factory-approved glass and panel tray. Utilizes industry leading JLG capacity to get materials to the work site. Improves productivity and reduces operator fatigue, while helping to protect panels from damage.

SkyCutter™ Package

Cut faster and cleaner with an on-board Miller® plasma cutter. Eliminate the potential dangers of Oxygen/Acetylene tanks and hoses draped over the railings. Add a SkyCutter™ Package to any unit equipped with the SkyPower™ Package.



SkyAir™ Package

Get the most out of your SkyPower® equipped boom lift with SkyAir™, JLG's on-board air compressor accessory. The generator-powered 13 CFM (9 CFM delivered) air compressor is mounted under the hood and utilizes the air line provided by the SkyPower® accessory.

Pipe Rack Accessory

JLG's exclusive Pipe Rack Accessory is designed to secure pipes close to where they are needed. The pipe rack is mounted to the top platform rail and can hold up to 180 lbs. (80 kg) of pipe.

Keep checking www.jlg.com for additional Workstation in the Sky™ accessories.

*Miller® is a trademark of Miller Electric.

JLG MODEL 800A/800AJ SERIES

PERFORMANCE FEATURES

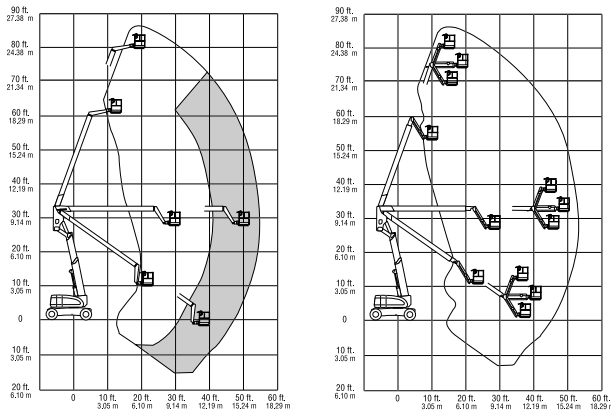

REACH SPECIFICATIONS

Platform Height	80 ft. (24.38 m)
Horizontal Reach (800A)	53 ft. (16.15 m)
Horizontal Reach (800AJ)	51 ft. 10 in. (15.8 m)
Up and Over Height	32 ft. 1 in. (9.78 m)
Swing	360 Degrees Continuous
Platform Capacity-Restricted (800A)	500/1000 lbs.* (227 kg/454 kg)
Platform Capacity-Unrestricted	500 lbs. (227 kg)
Platform Rotator	180 Degrees Hydraulic
Jib Length (800AJ)	6 ft. (1.83 m)
Jib Range of Articulation (800AJ)	130 Degrees (+70, -60)

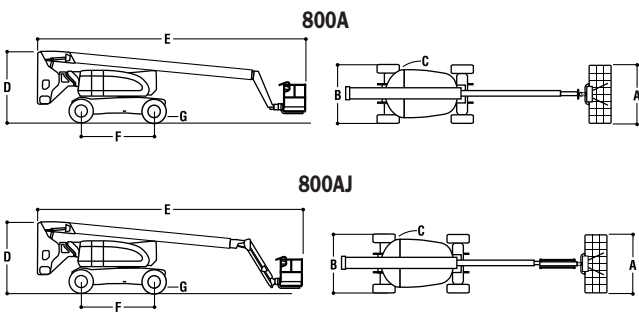

DIMENSIONAL DATA

A. Platform Size	36 in. x 96 in. (0.91 m x 2.44 m)
B. Overall Width	8 ft. (2.44 m)
C. Tailswing	2 ft. 6 in. (76 cm)
D. Stowed Height	9 ft. 10 in. (3.0 m)
E. Stowed Length (800A)	36 ft. 11 in. (11.25 m)
E. Stowed Length (800AJ)	36 ft. 6 in. (11.13 m)
F. Wheel Base	10 ft. (3.05 m)
G. Ground Clearance	12 in. (30 cm)
Gross Vehicle Weight**	33,100 lbs. (15,014 kg)
Max. Ground Bearing Pressure	76 psi (5.3 kg/cm ²)

CHASSIS

Drive Speed 2WD or 4WD	3.0 MPH (4.8 kph)
Gradeability 2WD	30%
Gradeability 4WD	45%
Turning Radius, (Inside/Outside)	
2WS	12 ft./22 ft. 6 in. (3.66 m/6.86 m)
4WS	7 ft./14 ft. 6 in. (2.13 m/4.42 m)
Tires/Type-2WD	Pneumatic 385/65 x 19.5
Tires/Type-4WD	Pneumatic 445/55 x 19.5

POWER SOURCE

Dual Fuel Engine, Ford LRG-425	82 hp (61 kW)
Diesel Engine, Deutz F4M1011F	65 hp (48 kW)
Diesel Engine, Caterpillar 3044C	63.3 hp (47.2 kW)
Fuel Tank Capacity	39 gal. (147.6 L)
Hydraulic Reservoir	40 gal. (151.4 L)
Auxiliary Power	12V DC

*Except CE rating. **Certain options or country standards will increase vehicle weight.

Standard Features

- 6 ft. (1.83 m) Articulating Jib (800AJ only)
- Platform: 36 in. x 96 in. (0.91 x 2.44 m) Side Entry
- Dual Rated Capacities (800A only)
- Oscillating Axle
- Inward Self-Closing Swinging Gate
- 180 Degree Hydraulic Platform Rotator
- 110V-AC Receptacle in the Platform
- 5 Degree Tilt Alarm/Indicator Light
- Swing-Out Engine Tray
- 12V-DC Auxiliary Power
- Hourmeter
- Control ADE™ System
- Proportional Controls
- Gull-Wing Engine Hood
- Hydrostatic Drive
- Operator Tool Tray
- Platform Console Machine Status Light Panel*
- Lifting/Tie Down Lugs
- Engine Distress Warning
- Rim Protector Lug Tread Tires
- Engine Distress Shutdown-Selectable via Analyzer
- All Motion Alarm

SkyPower™ Package

- 7500 Watt Generator
- 240/120V Single Phase
- 240V 3 Phase
- ½ in. Air Line to Platform

*Provides indicator lights at platform control console for system distress, 5 degree tilt light, and foot switch status.

Options

- 36 in. x 72 in. (0.91 x 1.83 m) Platform
- Mesh to Top Rail - Bolt-on Aluminum
- Light Package¹
- ½ in. (1.3 cm) Air Line to Platform
- Soft Touch System
- Foam Filled Tires
- 2500W Generator
- Tow Package
- Cold Weather Start Kit²
- Hostile Environment Kit³
- Platform Work Lights
- 43.5 lb. Propane Tank
- Flashing Beacon

1. Includes head and tail lights, and platform work lights.
2. Includes engine block heater (Ford and CAT) or glow plugs (Deutz standard on CAT), battery heater and oil tank heater.
3. Includes console cover, boom wipers and cylinder bellows.

Accessories

- SkyWelder™ Package** -Includes 250-amp Miller® welder in the platform, leads, clamp, stinger and fire extinguisher.
- Pipe Rack**-Platform mounted, 180 lbs. (80 kg) capacity.
- SkyGlazier™ Package** -Includes side-entry platform with glass and panel tray. (800A only).
- SkyCutter™ and SkyAir™ Package** -Includes Miller® plasma cutter mounted on platform and 9 CFM onboard air compressor.
- SkyWelder®/SkyCutter™, SkyAir™ Combination**
- SkyAir™ Package** -Includes 9 CFM onboard air compressor.

The JLG "1 & 5" Warranty for Models 800A & 800AJ

JLG Industries, Inc. backs our products with our exclusive "1 & 5" Warranty. We provide coverage on all products for one (1) full year, and cover all specified major structural components for five (5) full years. Due to continuous product improvements, we reserve the right to make specification and/or equipment changes without prior notification. This machine meets or exceeds applicable OSHA Regulations in 29 CFR 1910.67, 29 CFR 1926.453, ANSI A92.5-1992 and CSA B354.4-02 as originally manufactured for intended applications.

JLG Industries, Inc.

1 JLG Drive, McConnellsburg, PA 17233-9533
 Telephone 717-485-5161 Toll-free in US 877-JLG-LIFT
 Fax 717-485-6417
 www.jlg.com

Printed in USA
 FORM NO.: SS-800A-1202-10M
 PART NO.: 3131108
 REV. NO: R080406

